

PE-6000 USER

PCI Express x4/4-channel 2.5G LAN,
IEEE 802.3at Compliant Intel® I225 PoE+ PCIe Expansion Card

Manual

Record of Revision

Version	Date	Page	Description	Remark
0.10	2020/09/03	All	Preliminary Release	
1.00	2020/09/18	All	Official Release	
1.10	2023/06/21	5	Update	

Disclaimer

This manual is released by Vecow Co., Ltd. for reference purpose only. All product offerings and specifications are subject to change without prior notice. Vecow Co., Ltd. is under no legal commitment to the details of this document. Vecow shall not be liable for direct, indirect, special, incidental, or consequential damages arising out of the use of this document, the products, or any third party infringements, which may result from such use.

Declaration of Conformity

FCC This equipment has been tested and found to comply with the limits for a Class A digital device, pursuant to part 15 of the FCC Rules. These limits are designed to provide reasonable protection against harmful interference when the equipment is operated in a commercial environment. This equipment generates, uses, and can radiate radio frequency energy, and if it is not installed and used in accordance with the instruction manual, it may cause harmful interference to radio communications. Operation of this equipment in a residential area is likely to cause harmful interference in which case the user will be required to correct the interference at his own expense.

CE The products described in this manual comply with all applicable European Union (CE) directives if it has a CE marking. For computer systems to remain CE compliant, only CE-compliant parts may be used. Maintaining CE compliance also requires proper cable and cabling techniques.

Copyright and Trademarks

This document contains proprietary information protected by copyright. No part of this publication may be reproduced in any form or by any means, electric, photocopying, recording or otherwise, without prior written authorization by Vecow Co., Ltd. The rights of all the brand names, product names, and trademarks belong to their respective owners.

Order Information

Part Number	Description
PE-6004	Intel® I225 4-CH PCI Express Card with 2.5GigE PoE+

Table of Contents

CHAPTER 1	GENERAL INTRODUCTION	1
	1.1 Overview	1
	1.2 Features	1
	1.3 Product Specification	2
	1.4 Mechanical Dimension	3
	1.4.1 PE-6004	3
	1.4.2 PE-6004 With Heatsink	3
	1.4.3 PE-6004 With Heatsink and Fan	4
CHAPTER 2	GETTING TO KNOW YOUR PE-6000	5
	2.1 Packing List	5
	2.2 PE-6004 I/O and Indication	6
CHAPTER 3	GETTING START	10
CHAPTER 4	DRIVER INSTALLATION AND SETTING	12
	4.1 Driver Installation	12
	4.2 Jumbo Frame	16
	4.3 Link Aggregation	18
APPENDIX A	: PoE Guide	21
APPENDIX B	: Software Functions	25



GENERAL INTRODUCTION

1.1 Overview

PE-6004 is a 4-ports 2.5GigE PCIe Expressx4 Expansion Card, supporting IEEE 802.3at PoE⁺ up to 25.5W power output at 48V DC per port. Powered by Intel[®] I225 LAN chipset, PE-6004 adopts 4-port Independent 2.5GigE Ethernet controller and it supports up to 2.5Gbps data rate each port with teaming functions, Fault Tolerance, IEEE 802.3ad Link Aggregation and Load Balancing, up to 9KB Jumbo Frame. Vecow PE-6004 is an ideal PCIe expansion card for industrial applications in Scientific Research, real-streaming video, AI Surveillance, real-time inspection, and Industry 4.0/IIoT applications.

1.2 Features

- Intel[®] I225 2.5GBASE-T Ethernet Controller supports 4-port independent 2.5GigE LAN, up to 2.5Gbps data rate
- PCI Express x4 interface, PCIe 3.0 supports up to 8 GT/s
- Supports IEEE 802.3at Power over Ethernet (PoE⁺), up to 25.5W Power Output at 48V DC per port, with PoE⁺ On/Off Control
- IEEE 802.3bz (2500BASE-T), IEEE 802.3ab (1000BASE-T), IEEE 802.3u (100BASE-TX), and IEEE 802.3i (10BASE-TX) compliant
- Teaming features : Fault Tolerance, IEEE 802.3ad Link Aggregation and Load Balancing, up to 9KB Jumbo Frame
- Time Sensitive Network (TSN) features : IEEE 1588 Precision Time Protocol (PTP), IEEE 802.3AS Precision Timing Synchronization, IEEE 802.1Qav and 802.1Qbv
- Supports IEEE 802.3az Energy Efficient Ethernet (EEE) and DMA Coalescing Power Management features
- Integrated Switching Voltage Regulator (iSVR) and IEEE 802.1q VLAN supported
- -25°C to 60°C Operating Temperature

1.3 Product Specification

Ethernet	
Interface	PCI Express x4
Controller	4 Intel Ethernet Controller I225-LM
Data Rate	2.5Gbps/1Gbps/100Mbps/10Mbps
Jumbo Frame	Up to 9KB supported
Link Aggregation (LAG)	Present
Connector	RJ45 type
PoE Standard	IEEE 802.3at compliant
Power Requirements	
Output	<ul style="list-style-type: none">• 4 RJ45 PoE Port• 4 LED for PoE On/Off Mode• Up to 25.5W Power Output at 48V DC per port
Power Connector	1 4-pin ATX 12V Power Connector
Environment	
Operating Temperature	-25°C to 60°C with air flow (-40°F to 140°F)
Storage Temperature	-40°C to 85°C (-40°F to 185°F)
Humidity	5% to 95% Humidity, non-condensing
Relative Humidity	95% @ 55°C
Certifications	FCC, CE, RoHS compliant
Mechanical	
Dimension	168.0mm x 111.0mm (6.61" x 4.37")

1.4 Mechanical Dimension

1.4.1 PE-6004

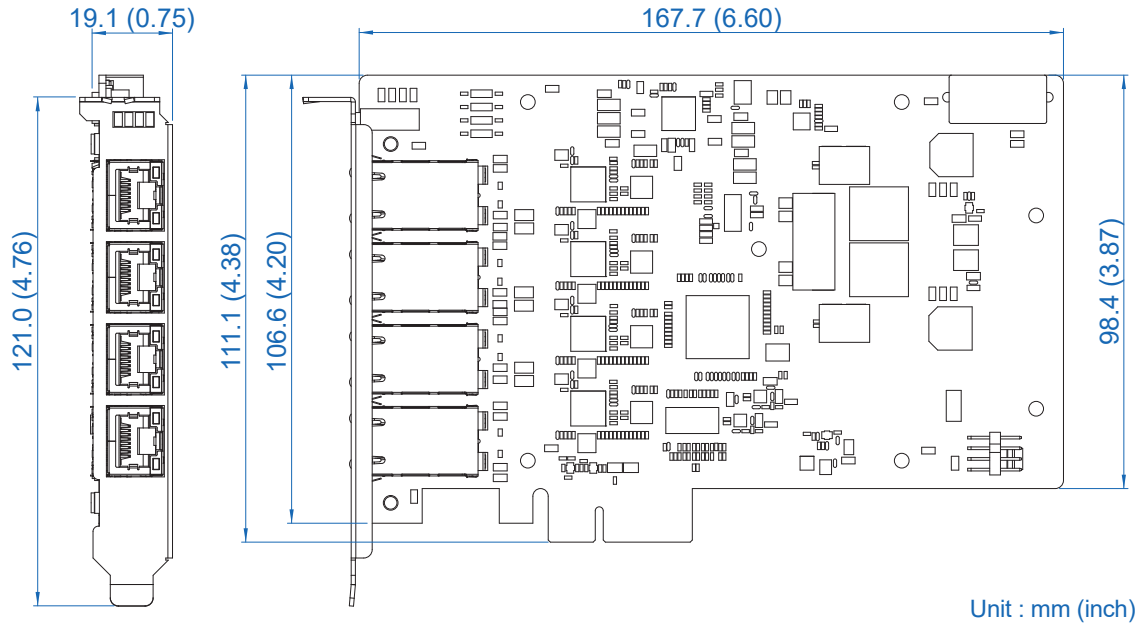

1.4.2 PE-6004 With Heatsink

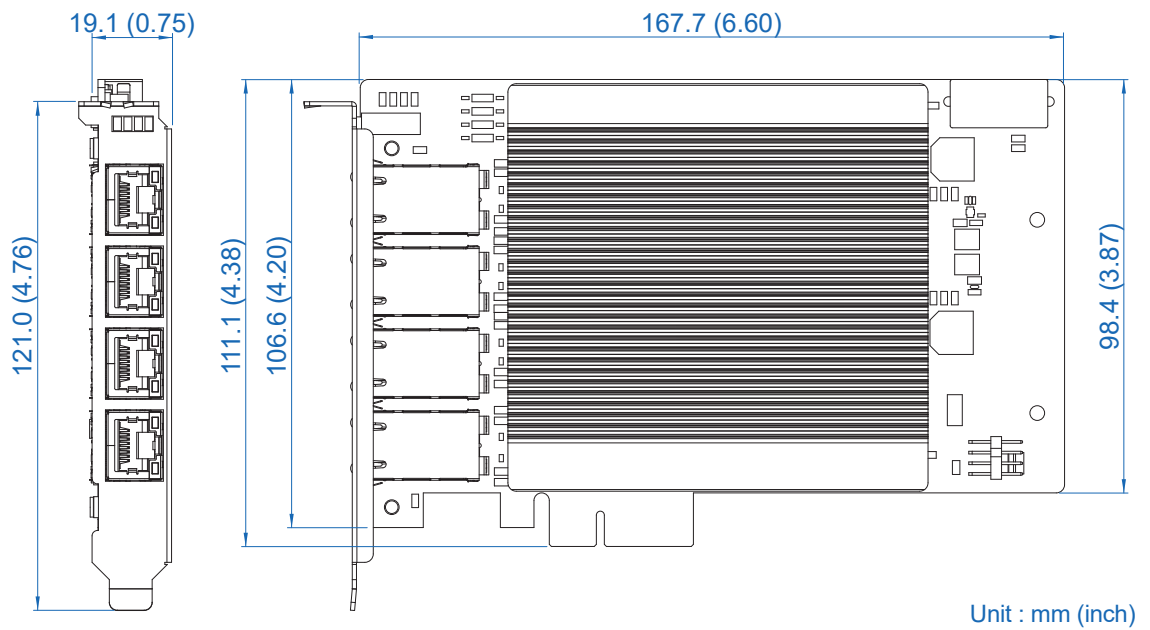

1.4.3 PE-6004 With Heatsink and Fan

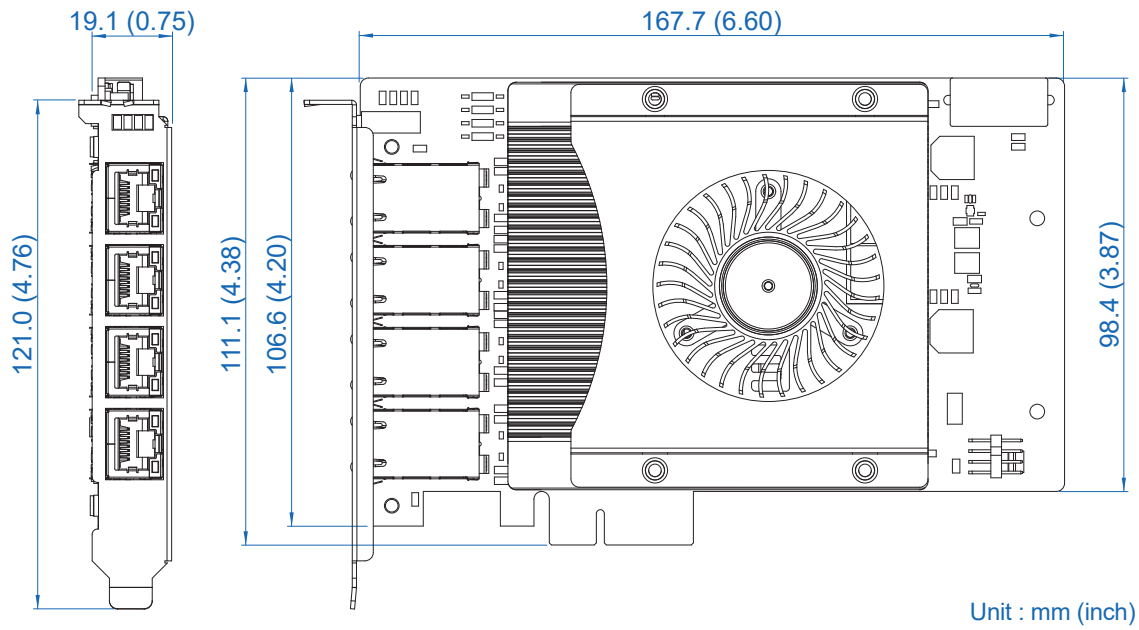

2

GETTING TO KNOW YOUR PE-6000

2.1 Packing List

Item	Description	Qty
1	PE-6004, Intel I225 4-port 2.5GigE PoE ⁺ PCI Express Expansion Card	1

2.2 PE-6004 I/O and Indication

2.2.1 PoE (Power over Ethernet) Ports

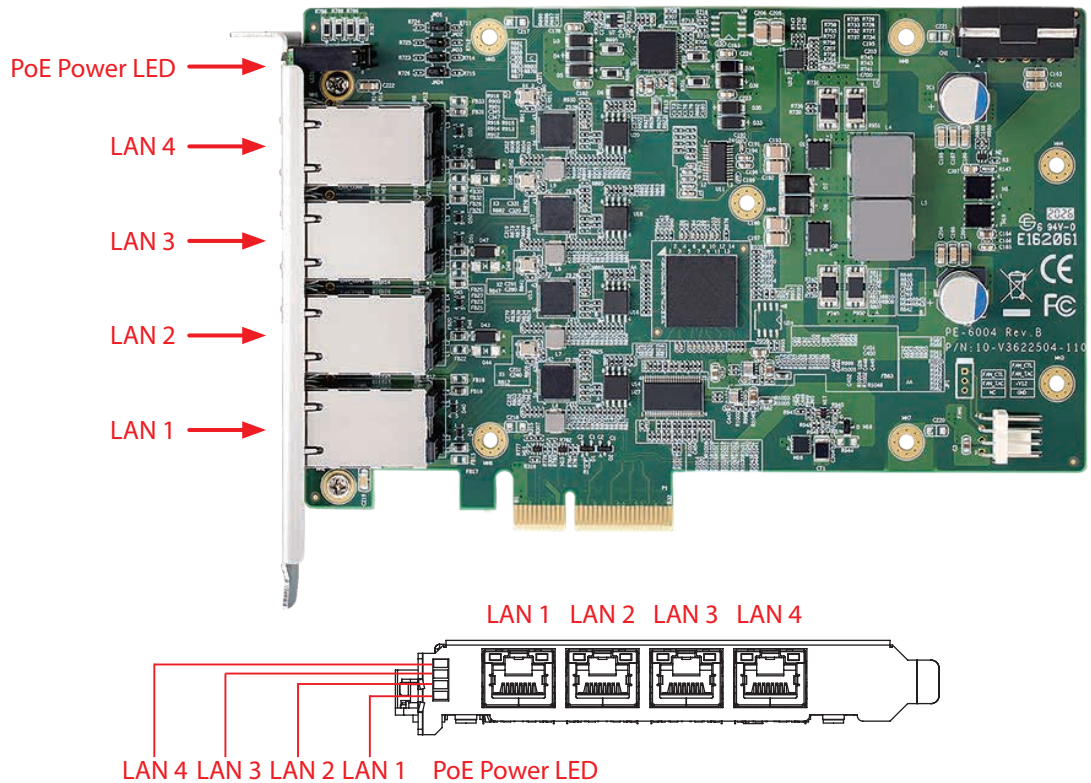

PE-6004 is equipped with 4 IEEE 802.3at PoE⁺ ports for transmitting power as much as 25.5W/48V per port and 1G/2.5G GBASE-T gigabit data signals over standard Ethernet CAT-5/CAT-6 cable.

Each PoE connection is powered by Intel[®] I225-LM 2.5GBASE-T Gigabit Ethernet.

Controller and independent PCI express interface to connect with multi-core processor for networking and data transmit optimization. Only when PoE port starts to supply power to power devices, the dedicated LED will be lightened.

The pin-outs of LAN 1 and LAN 4 are listed as follows :

Pin No.	10/100 Mbps	1000Mbps	PoE
1	E_TX+	MDI0_P	PoE+
2	E_TX-	MDI0_N	PoE+
3	E_RX+	MDI1_P	PoE-
4	----	MDI2_P	----
5	-----	MDI2_N	----
6	E_RX-	MDI1_N	PoE-
7	-----	MDI3_P	----
8	-----	MDI3_N	----

Each LAN port is supported by standard RJ-45 connector with LED indicators to present Active/Link/Speed status of the connection.

The LED indicator on the left bottom corner lightens in OFF when the cable is properly connected to a 10M/100Mbps Ethernet network; The LED indicator on the left bottom corner lightens in solid green when the cable is properly connected to a 1000Mbps Ethernet network; The LED indicator on the left bottom corner lightens in solid orange when the cable is properly connected to a 2.5Gbps Ethernet network The right LED will keep twinkling/off when Ethernet data packets are being transmitted/received.

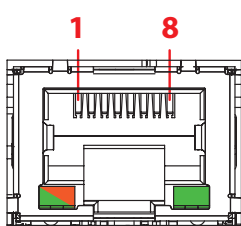

LED Status	10M/100Mbps	1000Mbps	2.5Gbps
Right LED	Flash Green	Flash Green	Flash Green
Left LED	off	Solid Green	Solid Orange

PoE LED	LED Color	PoE Status
LED1-4	Solid Green	PoE On

2.2.2 Power Input

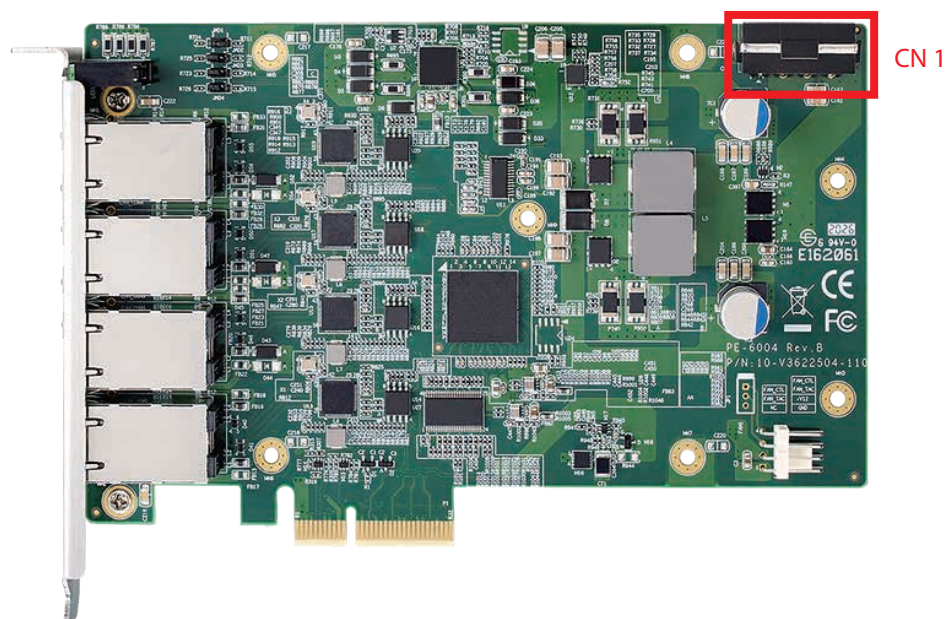

The PE-6004 is also equipped with one 4-pin power plug (12V, 6A max) for additional power supply. For most cases, the power obtained from PCIe bus is sufficient for the PoE devices, and you do not need to supply extra power to the card. In case the external power is needed, you can use 4-pin ATX power connector (+5V/Red, GND/Black, GND/Black, +12V/Yellow) inside the host computer. Please always confirm the polarity before you plug into the onboard 4-pin power plug.

CN1 :

Pin No.	Definition	Pin No.	Definition
1	NC	3	GND
2	GND	4	+12V

2.2.3 PoE Power On/Off

JAD1 - JAD4

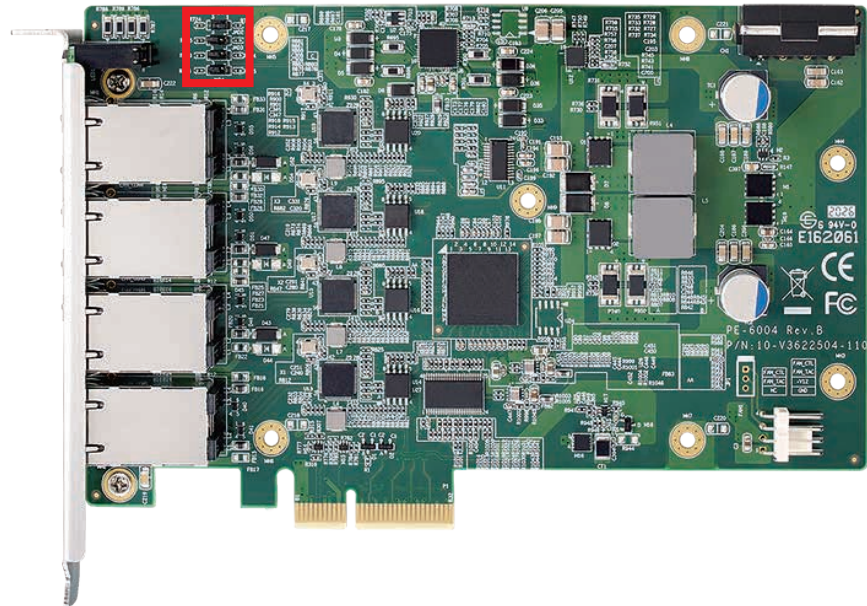

PE-6004 controls PD69104B PoE Power ON/OFF via SMBUS. Jumper JAD1~JAD14 address setting as below (1-2=H , 2-3=L) :

<div style="text-align: center;"> </div>				
JAD4	JAD3	JAD2	JAD1	Address
2-3	2-3	2-3	2-3	0x40
2-3	2-3	2-3	1-2	0x42 (Default)
2-3	2-3	1-2	2-3	0x44
2-3	2-3	1-2	1-2	0x48
2-3	1-2	2-3	2-3	0x4A
2-3	1-2	2-3	1-2	0x4C
2-3	1-2	1-2	2-3	0x4E
2-3	1-2	1-2	1-2	0x50
1-2	2-3	2-3	2-3	0x52
1-2	2-3	2-3	1-2	0x54
1-2	2-3	1-2	2-3	0x56
1-2	2-3	1-2	1-2	0x58
1-2	1-2	2-3	2-3	0x5A
1-2	1-2	2-3	1-2	0x5C
1-2	1-2	1-2	2-3	0x5E

2.2.4 Fan Connector

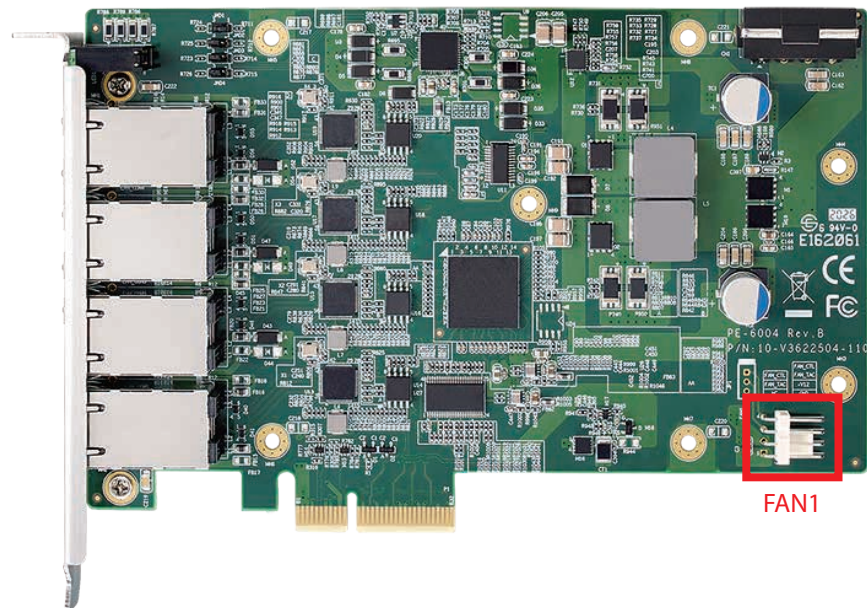

Fan power connector supports for additional thermal requirements. The pin assignments of FAN1 is listed in the following diagram :

Pin input :

	Pin No.	Definition	Pin No.	Definition
	1	GND	2	+12V (1.5A max)
	3	-----	4	-----

3

GETTING START

Step 1. Insert PE-6000 golden finger and PCI bracket into PCIe socket carefully.

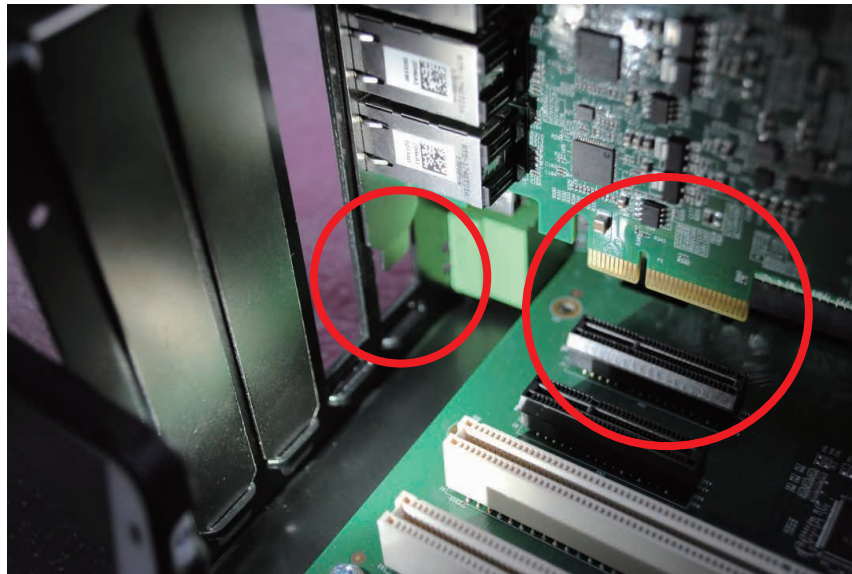

Step 2. Make sure golden finger and PCI bracket are inserted smoothly.

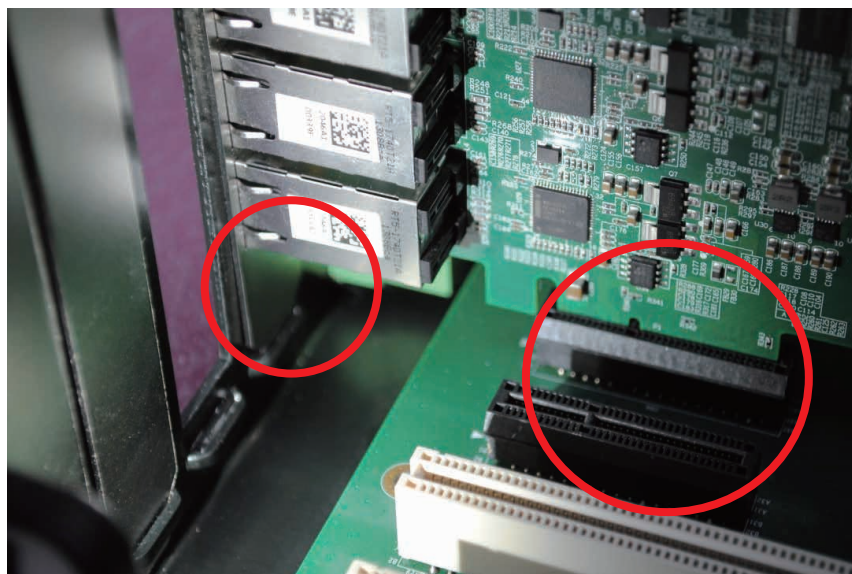

Step 3. Make sure the bracket aligns screw hole.

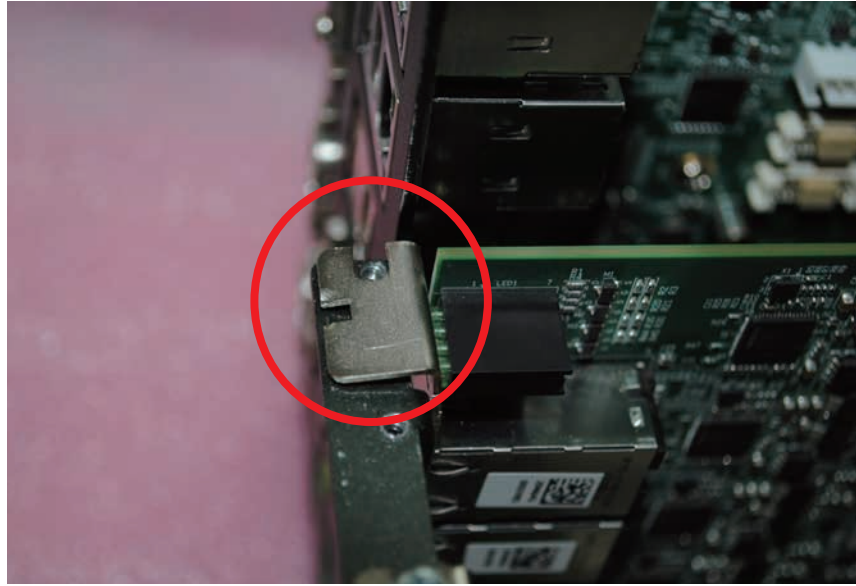

Step 4. Fasten the M3 or #6-32 screw.

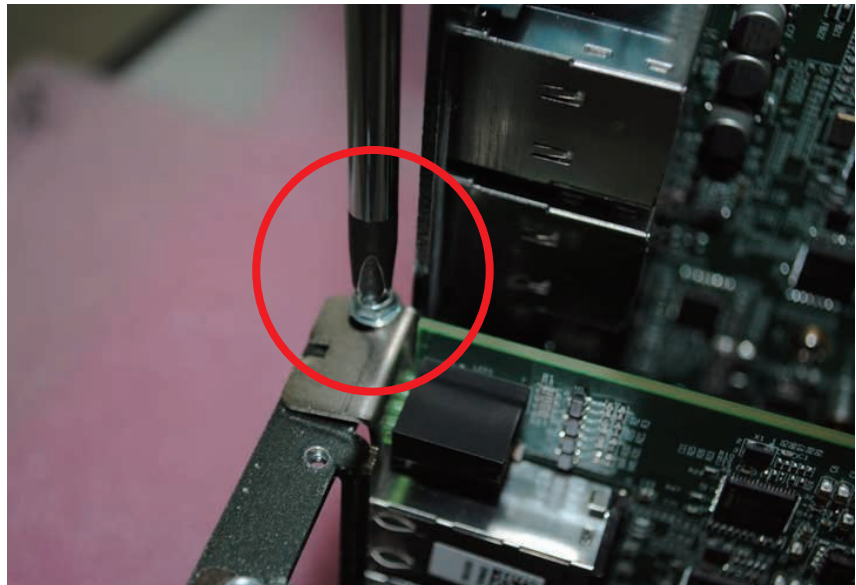

4

DRIVER INSTALLATION AND SETTING

4.1 Driver Installation

This section describes :
How to install drivers for PE-6004 PoE Card.

System OS :
Windows 10-64bit

Step 1. Execute "Intel PROWin64.exe (25.1 Later version)" and then go "Next" step.

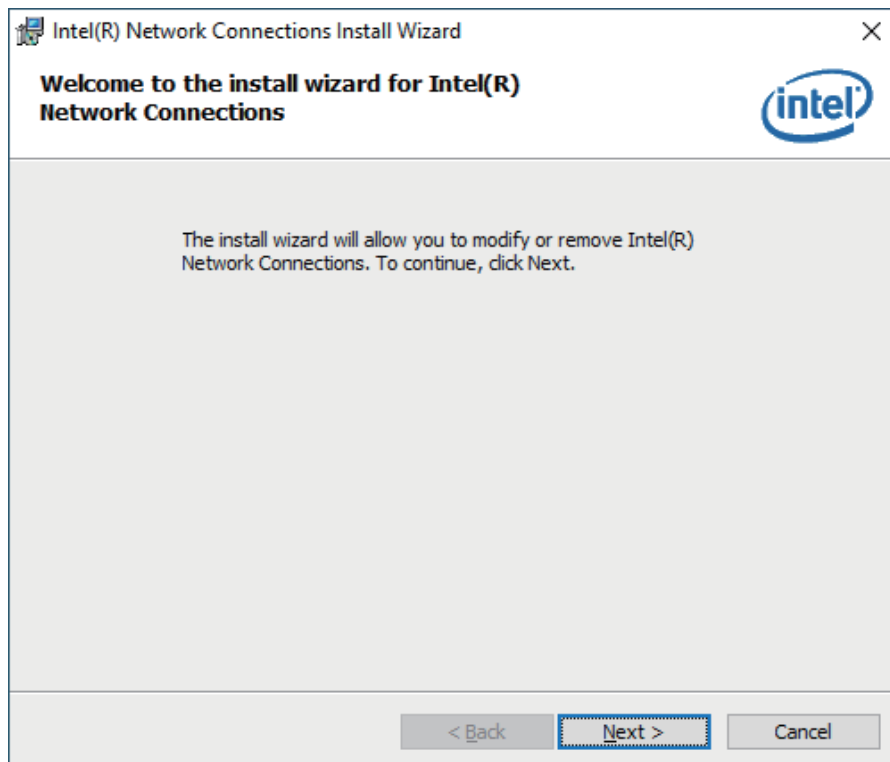

Step 2. Select "Modify" and then go to "Next" step.

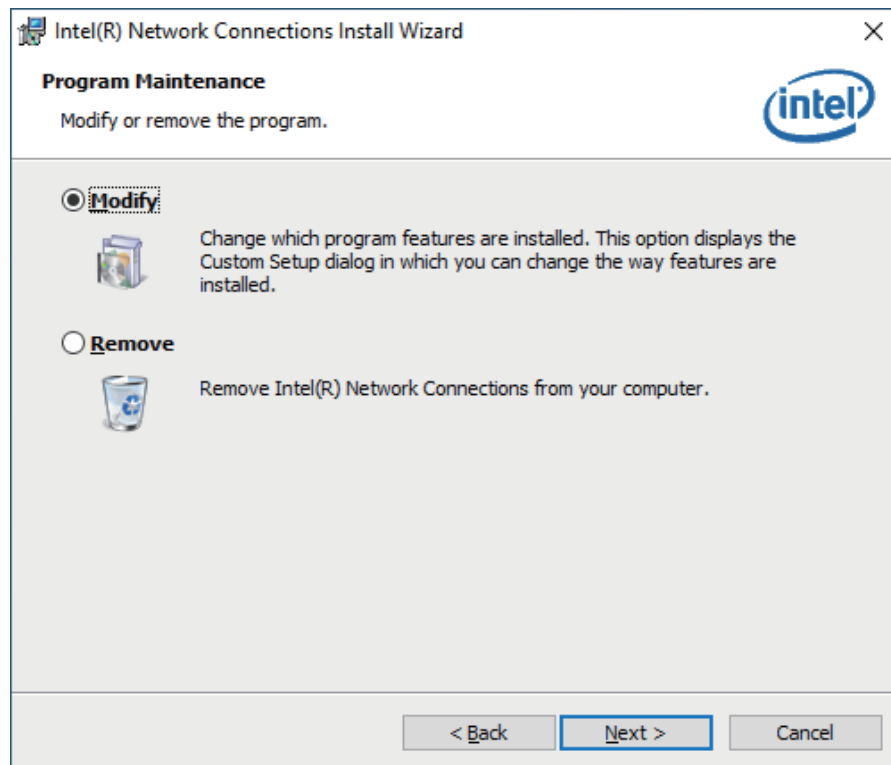

Step 3. Select "Next" step.

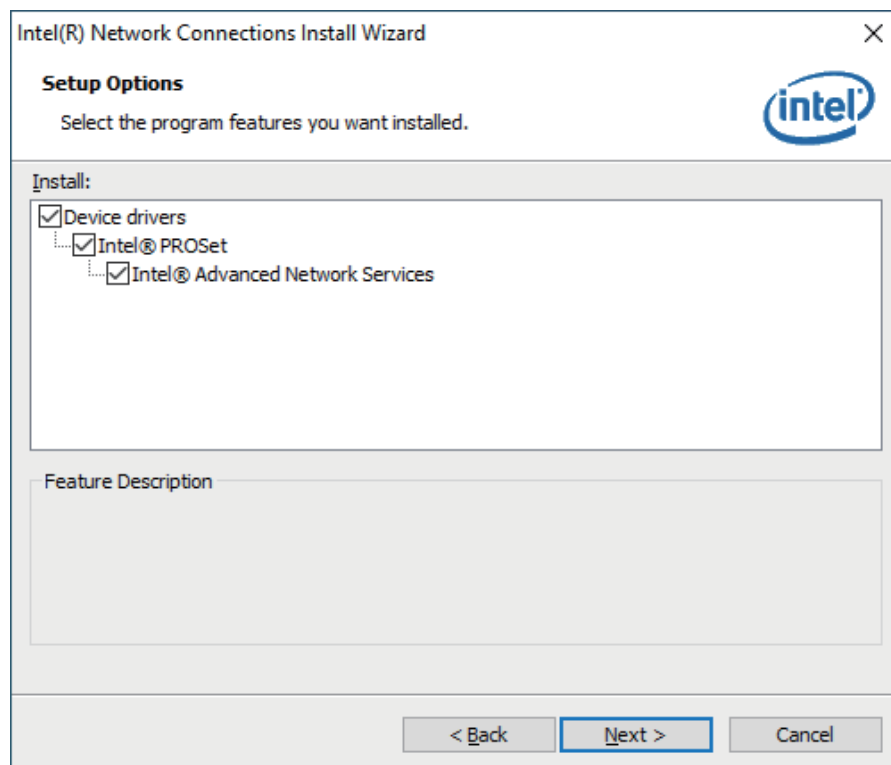

Step 4. Click the "Install" icon to begin the installation.

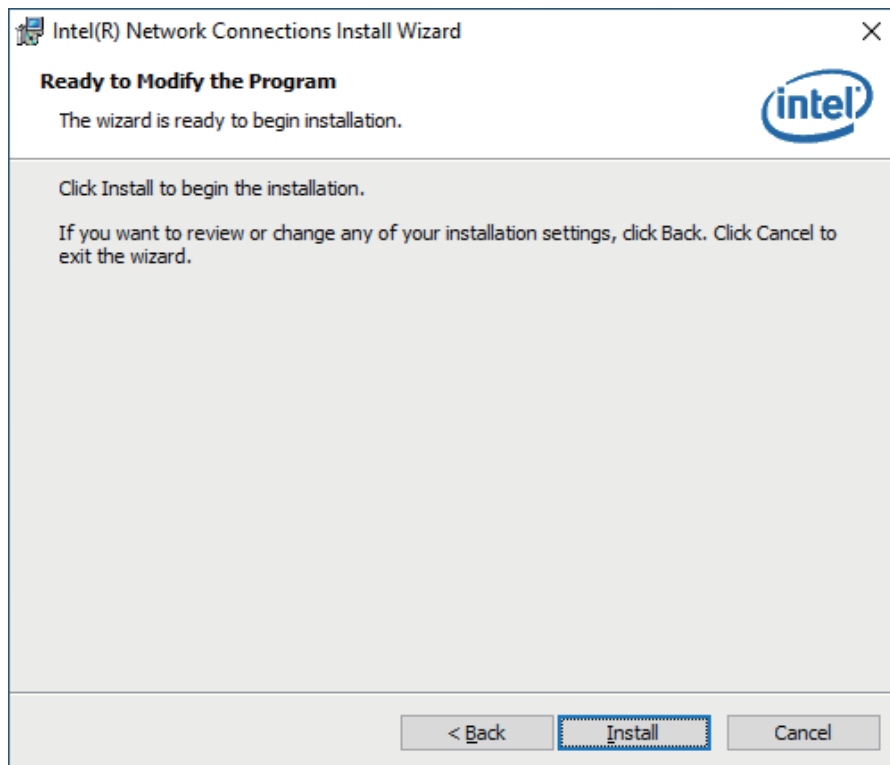

Step 5. Install wizard completed.

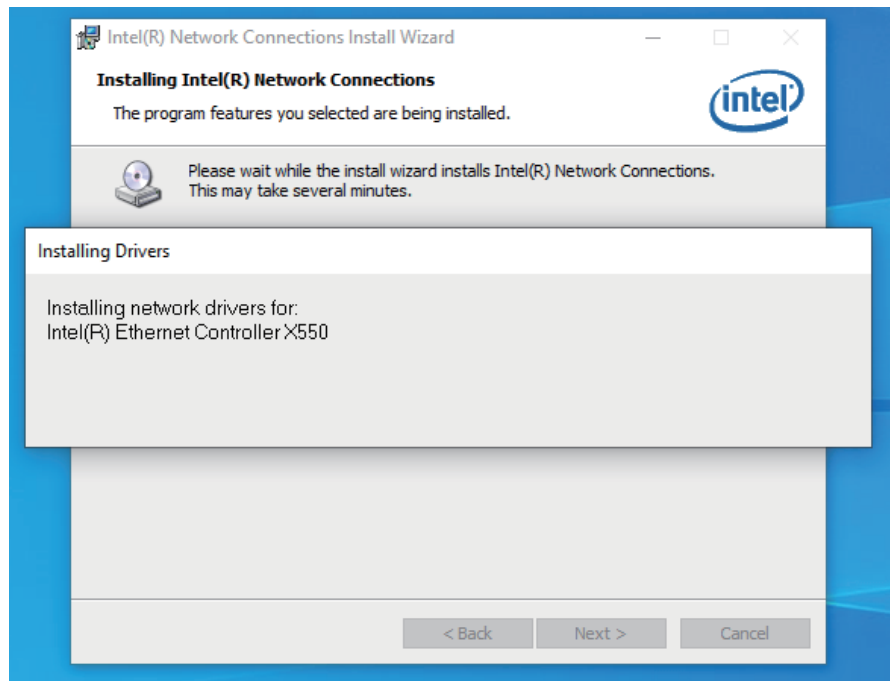

Step 6. Select "Finish" step.

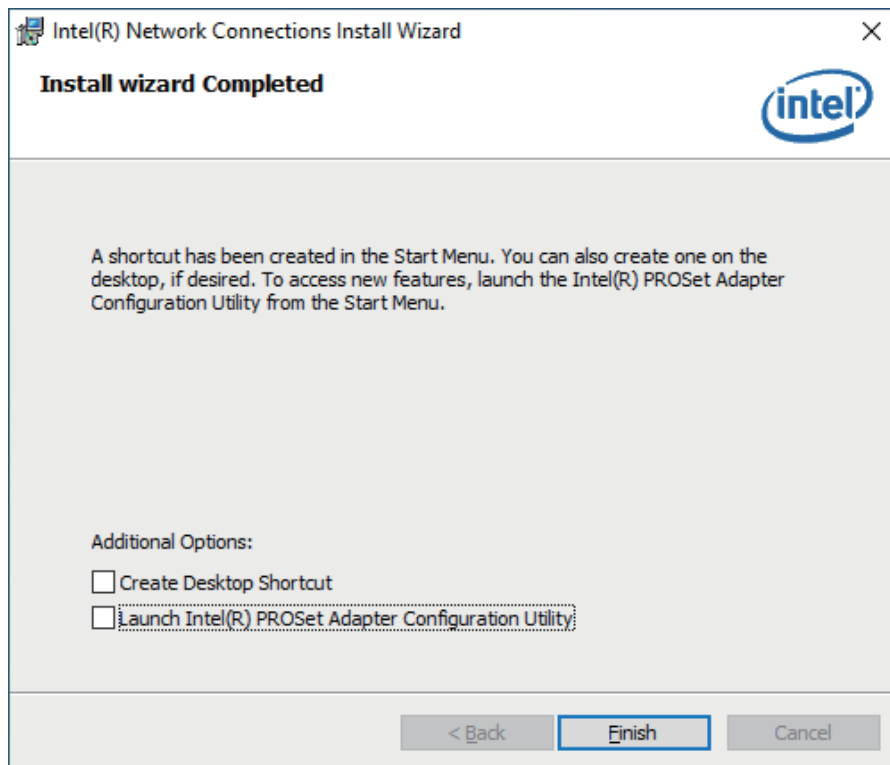

Once you need this network driver, you could remove this program on Control panel directly.

4.2 Jumbo Frame

After installing the driver for Intel® I225-LM controller, you can get the enhance function that called jumbo frame, please find more instruction as below.

Step 1. "Right-click  → Device Manager → Network adapters".

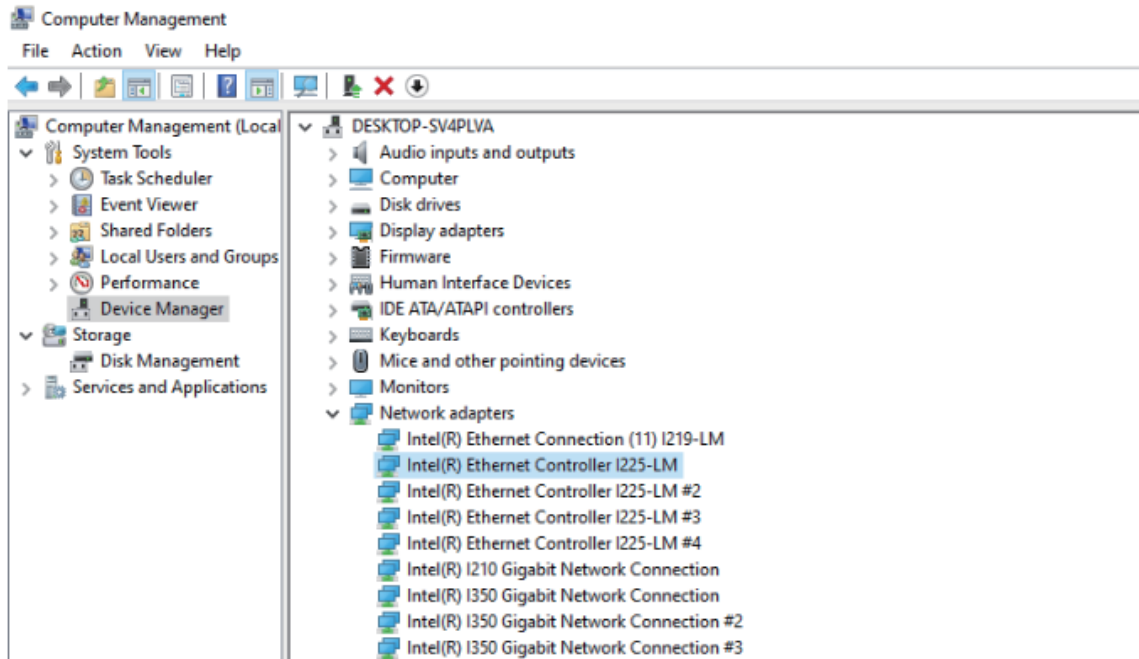

Step 2. Select anyone "Intel Ethernet Converged Network Adapter I225-LM #xx", right Click and select "Properties", a property dialog appears and Click on the Advanced page.

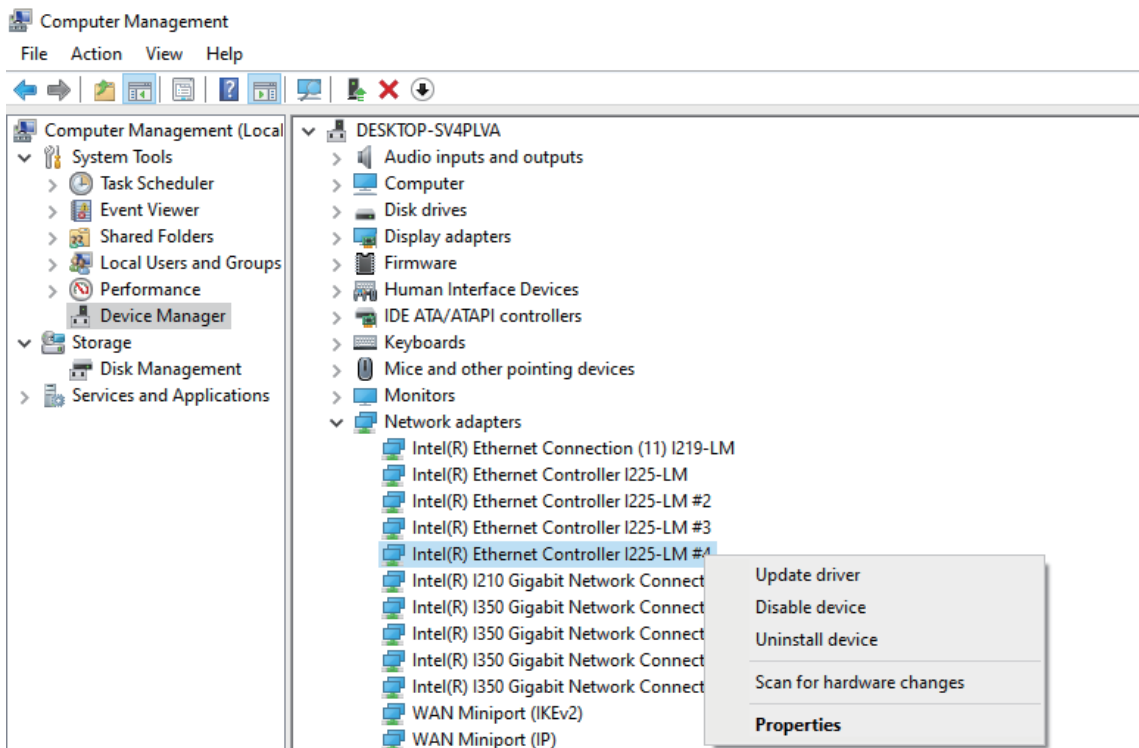

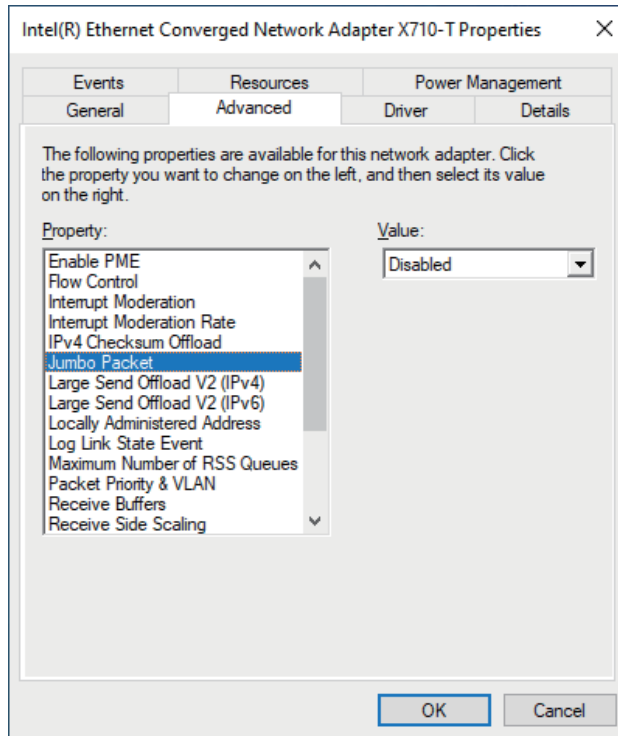

Step 3. Select the "Jumbo Packet", settings, and select the expected jumbo frame size.

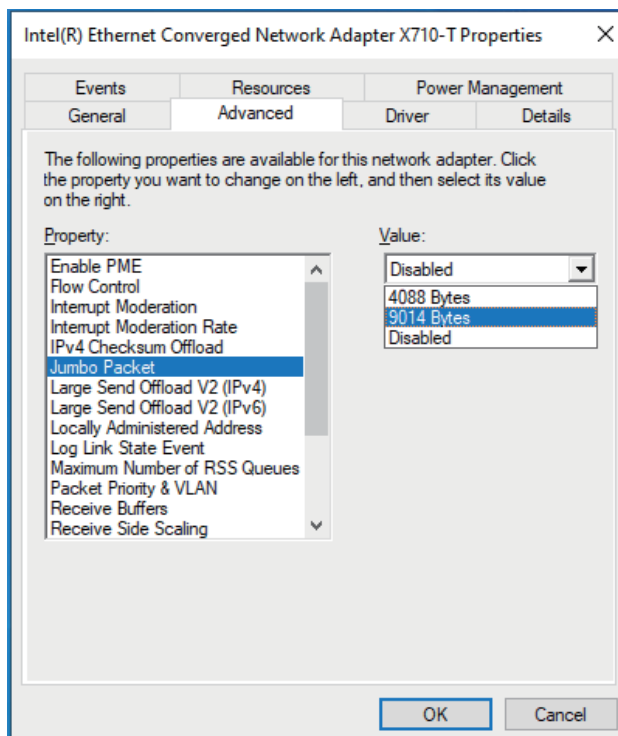

4.3 Link Aggregation

Step 1. Here shows another enhance network function "Teaming".

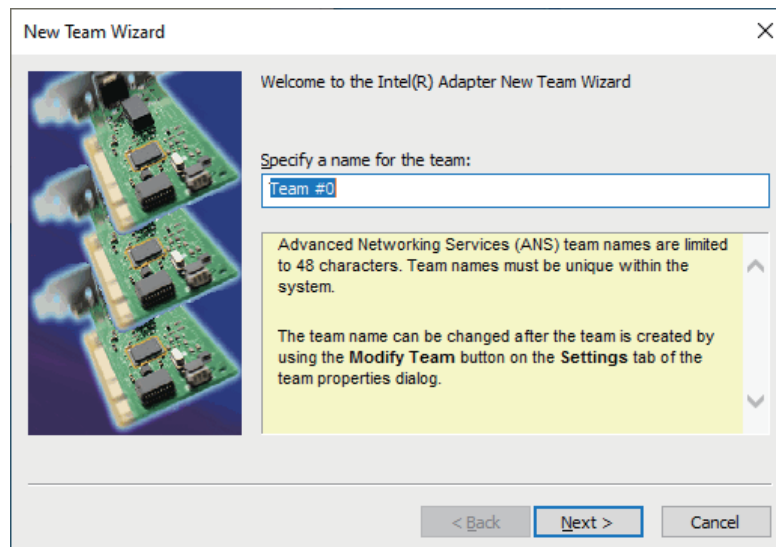
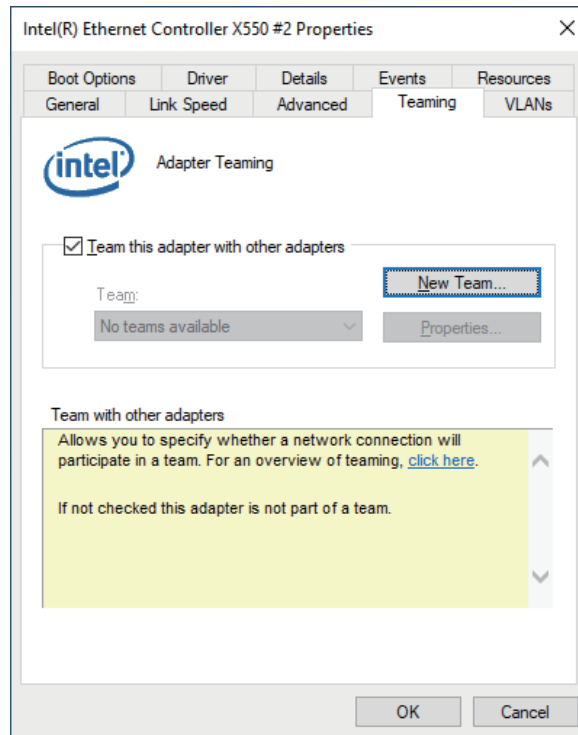

Step 2. You could multi-select network device to get a high performance net.

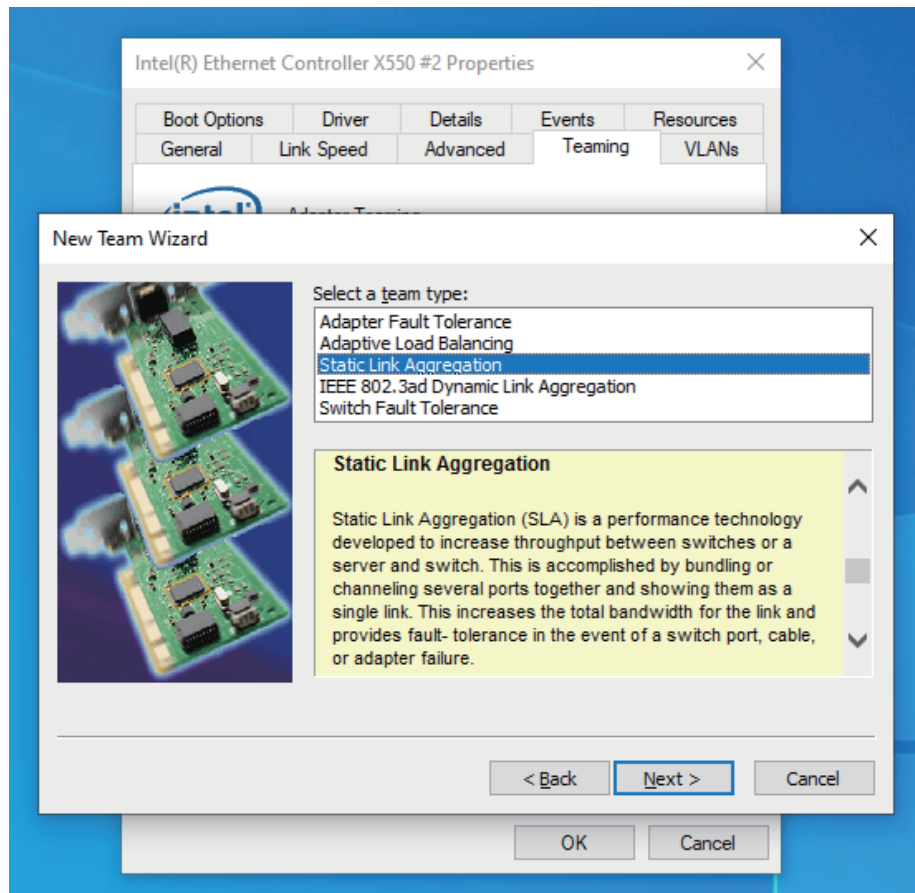
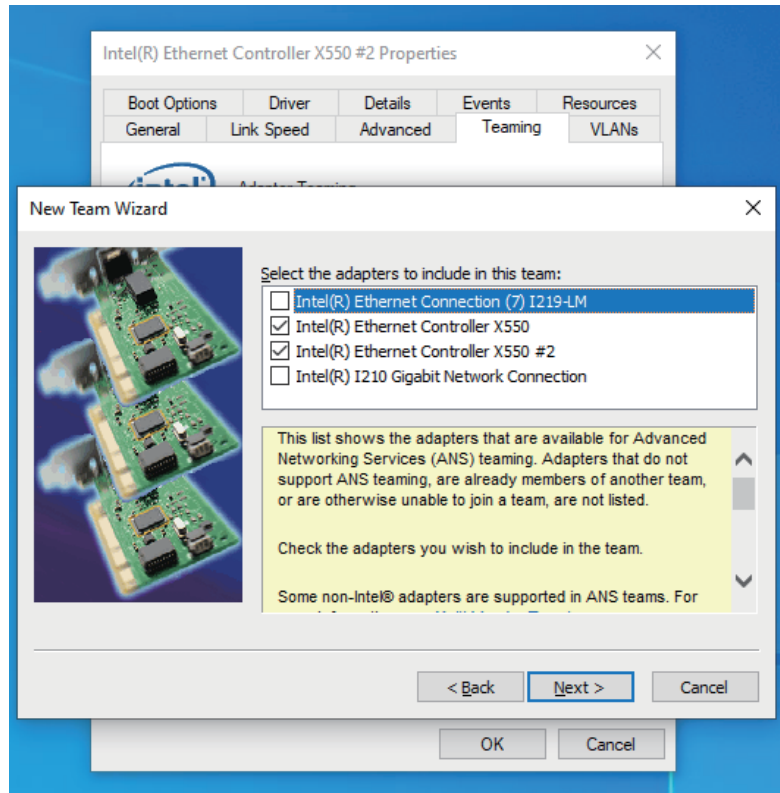

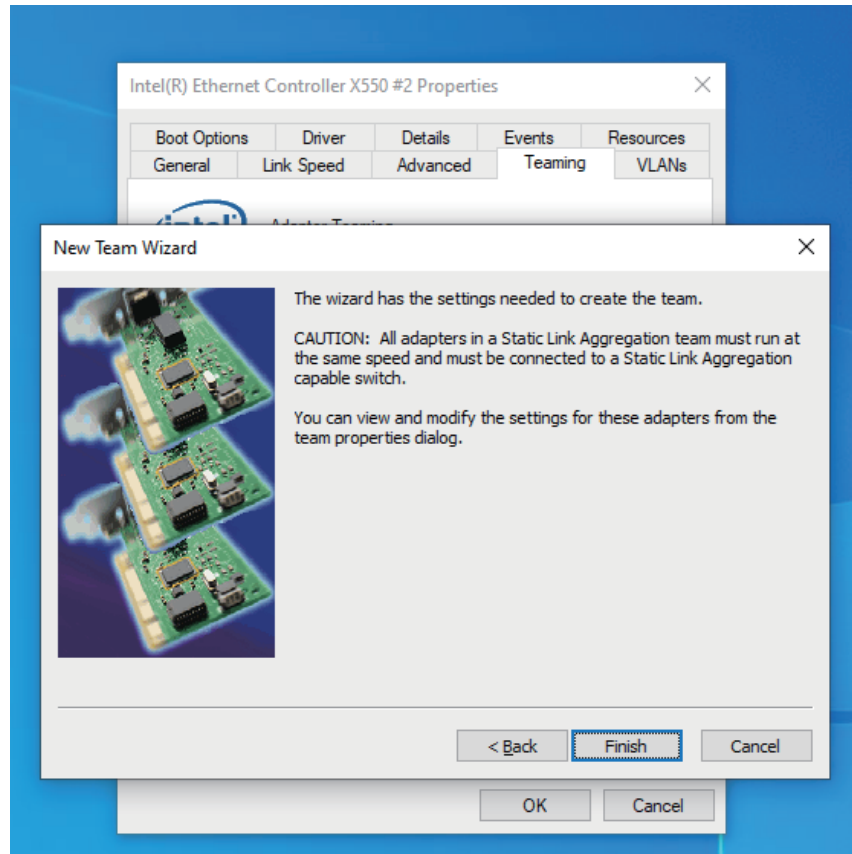

A

APPENDIX A : PoE Guide

A.1 Function Description

The PE-6004 series offers a 4-port PoE⁺.

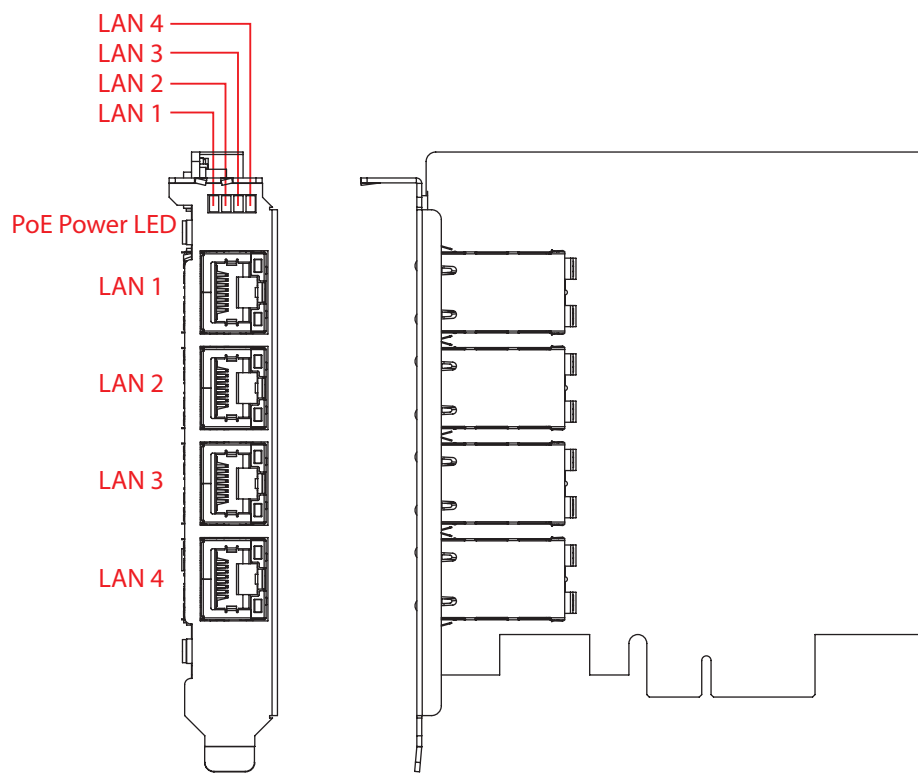

Pin No.	Definition	Pin No.	Definition
LAN 1	POE 0	LAN 3	POE 2
LAN 2	POE 1	LAN 4	POE 3

Do NOT use these functions in below :

1. ECS-4000 : DIO1 (ID = 2), POE (ID = 0)
2. ECS-4500, ECS-9000, ECS-9200, ECS-9700, IVH-7700, IVH-9000, IVH-9200 : POE (ID = 0)
3. RCS-7000 : GPIO (ID = 0)
4. PE-2000 : DIO1 (ID is the same, ID = 0 ~ 7), POE (ID = 0)
5. UE-1000 : USB (IDUE-1000 = IDPE-3000 >> 1 & 3 | IDPE-3000 << 2 & 4)

PoE ON/OFF vs Slave address setting as below :

PE-6004 controls PD69104B PoE Power ON/OFF via SMBUS. Jumper JAD1~JAD14 address setting as below (1-2=H , 2-3=L) :

JAD4	JAD3	JAD2	JAD1	Address
2-3	2-3	2-3	2-3	0x40
2-3	2-3	2-3	1-2	0x42 (Default)
2-3	2-3	1-2	2-3	0x44
2-3	2-3	1-2	1-2	0x48
2-3	1-2	2-3	2-3	0x4A
2-3	1-2	2-3	1-2	0x4C
2-3	1-2	1-2	2-3	0x4E
2-3	1-2	1-2	1-2	0x50
1-2	2-3	2-3	2-3	0x52
1-2	2-3	2-3	1-2	0x54
1-2	2-3	1-2	2-3	0x56
1-2	2-3	1-2	1-2	0x58
1-2	1-2	2-3	2-3	0x5A
1-2	1-2	2-3	1-2	0x5C
1-2	1-2	1-2	2-3	0x5E

A.2 Software Package Contain

Distribution folder include x32 and x64 versions, use batch file for installation.

There are included as followed :

Win7_32.bat :

Installation for 32-bit driver

Win7_64.bat :

Windows update package which driver required (need to restart), and Installation for 64-bit driver

Win8_32.bat, Win8_64.bat :

Installation for driver, and guideline to Framework 3.5 distribution for sample

Win10_32.bat, and Win10_64.bat :

Installation for driver, and installation to Framework 3.5 distribution for sample

Uninstall_32.bat, and Uninstall_64.bat :

Uninstallation for driver

Run batch file as Administrator.

Support Windows 7 above.

Make sure it is Windows version before installation.

Runtime folder includes head file for software developer or System Integration.

Sample folder includes sample program, driver library, and API library. Source

folder includes sample program source code that compile on Visual Studio 2008.

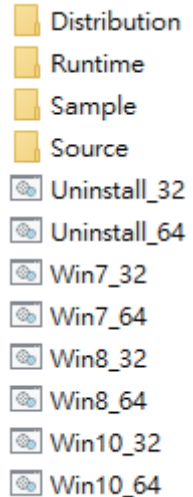

A.3 Sample

Sample folder include x32 and x64 versions, as shown below :

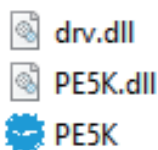

Sample PE5K.exe, as shown below :

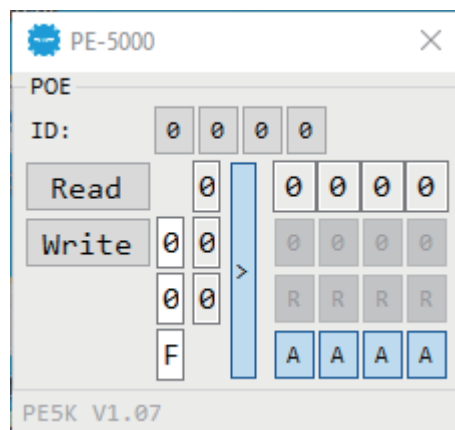

POE group :

Read button :

Set POE configuration to get POE state.

Write button :

Set POE configuration to set POE state.

POE output text :

User setting, POE output state by hexadecimal bitmask - on/off.

Use for Write button activate.

POE writable text :

User setting, POE writable of POE configuration by hexadecimal bitmask - yes/no.

Use for Write button activate.

POE mode text :

User setting, POE mode of POE configuration by hexadecimal bitmask - Auto/Manual.

Use for Write button activate.

POE input text (read only) :

POE input state by hexadecimal bitmask - on/off.

Use for Read button activate.

POE text (read only) :

POE output state with input state and configuration.

Use for Write button activate.

POE output text (read only) :

POE output state with configuration.

Use for Write button activate.

POE input port texts (read only, port 4 ~ port 1) :

POE input port state

Use for Read button activate.

POE output port check button(port 4 ~ port 1) :

User setting, POE output port state

Use for Write button activate.

POE port writable check button(port 4 ~ port 1) :

User setting, POE port writable of POE configuration.

Use for Write button activate.

POE port mode check button(port 4 ~ port 1) :

User setting, POE port mode of POE configuration.

Use for Write button activate.

B

APPENDIX B : Software Functions

B.1 Driver API Guide

In Runtime folder, on PE6K.h :

`_DLL_IMPORT_` definition is used on LoadLibrary API for PE5K.dll. `PE6K_EXPORTS` definition is used on PE5K.dll building.

BOOL Initial(BYTE Scan, BYTE ID)

Initial card for POE

Scan : POE ID scan type

2 : Auto scan; 1 : Manual setup; 0 : Not detect ID ([3:0]) : POE ID by manual setting

Return :

TRUE (1): Success;

FALSE (0): Fail (Driver not exists, or out of range error, or initial error (version is too old, or card not match))

BOOL GetPOEConfig(BYTE ID, BYTE *Auto, BYTE *Mask)

Get POE configuration (by variable) ID ([3:0]) : POE ID

Auto ([3:0]) : Auto mode, pin setting by hexadecimal bitmask

1 : Auto;

0 : Manual

Mask ([3:0]): DC Enable/Disable, pin setting by hexadecimal bitmask

1 : Enable;

0 : Disable

Return :

TRUE (1) : Success;

FALSE (0) : Fail (Initial error, or call by pointer error, or hardware problem)

BOOL SetPOEConfig(BYTE ID, BYTE Auto, BYTE Mask)

Set POE configuration ID ([3:0]) : POE ID

Auto ([3:0]): Auto mode, pin setting by hexadecimal bitmask

1 : Auto;

0 : Manual

Mask ([3:0]): DC Enable/Disable, pin setting by hexadecimal bitmask

1 : Enable;

0 : Disable

Return :

TRUE (1) : Success;

FALSE (0) : Fail (Initial error, or out of range error, or hardware problem)

BOOL GetPOE(BYTE ID, BYTE *POE)

Get POE input

ID ([3:0]) : POE ID

POE ([3:0]) : POE state, pin setting by hexadecimal bitmask

1 : On;

0 : Off

Return :

TRUE (1) : Success;

FALSE (0) : Fail (Initial error, or call by pointer error, or hardware problem)

BOOL SetPOE(BYTE ID, BYTE POE)

Set POE output

ID ([3:0]) : POE ID

POE ([3:0]) : POE state, pin setting by hexadecimal bitmask

1 : On;

0 : Off

Return :

TRUE (1) : Success;

FALSE (0) : Fail (Initial error, or out of range error, or hardware problem)



For further support information, please visit www.vecow.com

This document is released for reference purpose only.

All product offerings and specifications are subject to change without prior notice.

No part of this publication may be reproduced in any form or by any means, electric, photocopying, or recording, without prior authorization from the publisher.

The rights of all the brand names, product names, and trademarks belong to their respective owners.

© Vecow Co., Ltd. 2020. All rights reserved.